

## Model BV54 Rate of Flow Control Valve

### Description

The Model BV54 Brodie Rate of Flow Control Valve is normally opened and designed to maintain a controlled flow rate within +/-2%.

The pilot is balanced, single seated valve with large ports and will operate on a differential as low as 5 psi (34.5 kPa).

### Principle of Operation

The Model BV54 valve is pilot operated and operates on a balanced piston principle, spring biased to a closed position. Pressure differential overcomes the force of the spring, causing the main valve to open and establish flow. The Rate of Flow (Flow Limiting) Valve is normally open and throttles toward a closed position on increasing differential pressure.

### Design Features

- Modular construction -all internal parts including seat ring can be removed with the cylinder assembly without disturbing line connections.
- No diaphragms or stuffing boxes
- 45° body design assures high capacity
- Positive shut-off
- Uniform speed of response
- Linear control characteristics
- Inherently checks reverse flow
- O-Ring plus metal-metal seat
- Characterized ports for better low flow response

### Applications

The Model BV54 is normally used to control flow rate through a metering device; however, it can be utilized in any application requiring accurate, dependable flow control.

### “AP” (Aggressive Products) Option

The “AP” Option valve cylinder incorporates a combination of seals and o-ring materials to



### WARNING

Do NOT operate this instrument in excess of the specifications listed. Failure to heed this warning could result in serious injury and/or damage to the equipment.

provide optimum performance in aggressive product applications. Specify “AP” Option at time of order when valve is to be used on products which may affect standard seals.

### Materials of Construction

**Main Valve Body:** Steel - ASTM-A216-GR-WCB

**Main Valve Cylinder:** 17-4 PH Stainless Steel,  
Heat Treated

**Main Valve Piston:** Stainless Steel

**Seat Ring:** Stainless Steel

**O-Rings:** Viton (Standard), Other Materials  
(Optional)

**Other Internal Parts:** Stainless Steel

**Pilot Valve Strainer/Needle Valve Body:** Steel  
(Standard)

**Tubings and Fittings:** Steel (Standard), Stainless  
Steel (Optional)

## Optional Equipment

- Valve Position Indicator
- Position Indicator Switches
- Independent Opening Speed Control
- Stainless Steel Tubing
- Thermal Relief
- Additional Pilot Control Functions
- Excess Flow Shutoff (Pressure Sensitive)
- Pilot Line Isolation Block Valves
- Fusible Link Pilot Valve (closes at 160°F)
- Manual Override (opens valve)
- Epoxy Coating main Valve Body Unmachined Surfaces
- Orifice Flange

## Recommended Spare Parts

O-Rings

## Pilot Spring Ranges

150-300 lb. Valves	
(PSI)	(kPa)
0-20	0-138
*0-40	0-276
30-80	207-552
70-180	483-1241

\* Spring selection based on control pressure set point.

## Shipping Weight and Volume

Shipping Weight and Volume (Approximate)	
2"	69 lbs. @ 3 Cu. Feet 31.3 kgs. @ .085 Cu. Meters
3"	105 lbs. @ 2.36 Cu. Feet 47.63 kgs. @ .067 Cu. Meters
4"	140 lbs. @ 2.51 Cu. Feet 63.5 kgs. @ .071 Cu. Meters
6"	250 lbs. @ 4.84 Cu. Feet 113.4 kgs. @ .137 Cu. Meters

## Flange Connections/Ratings (ANSI)

Valve Size	Connections	Max Working Pressure @100F
2" - 6"	150 lb. ANSI	285 PSI
	300 lb. ANSI	740 PSI

Temperature Range : -20F to 150F (-29C to 66C)

## Valve Capacity Data

Valve Size	2"	3"	4"	6"
*Cv-gpm	90	190	315	700

\*Cv based on wide open valve utilizing water at 60F (15.6C).

## Ordering Information

When ordering, the following information must be supplied:

- Size
- Flange Connections
- Product, Product Viscosity, Product Specific Gravity
- Minimum and Maximum Flow Rate
- Minimum, Normal and Maximum Operating Temperature
- Control Functions to be Performed
- O-Ring Material
- Control Pilot Materials
- Tubing Material
- Pilot Spring Range
- Pilot Spring Setting (psi or kPa)

## Typical Installation

### Full Open - No Control

The Pilot is full open. Differential pressure (P4 minus P1) is less than the pilot spring setting. Y-port (P3) is open to Z-port (P2). The valve is floating the stream and is not required to control.

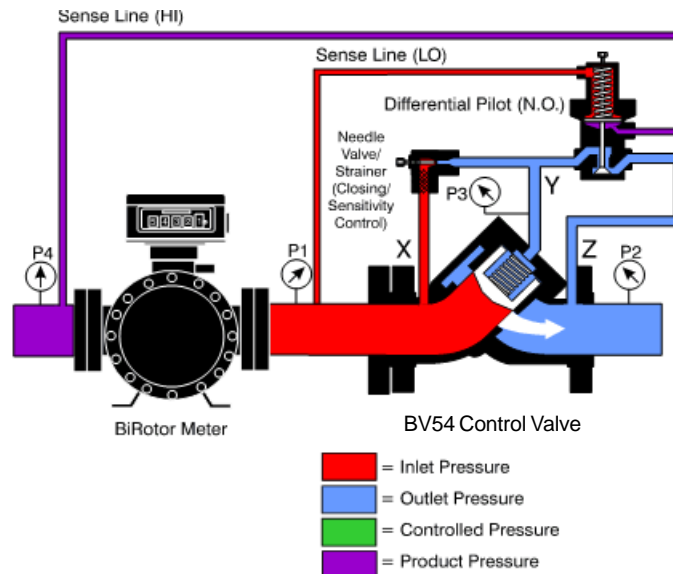

### Open - Controlled Position

The pilot is partially open. Differential pressure (P4 minus P1) has slightly exceeded the pilot spring setting. Z-port (P2) is being squeezed off by the throttling of the pilot, placing higher pressure on Y-port (P3). The increasing pressure at Y-port (P3) plus the main valve spring force establishes a position of the valve piston such that it balances differential pressure (P4 minus P1) equal to the pilot setting (plus or minus 2 psid), which is proportional to the flow rate.

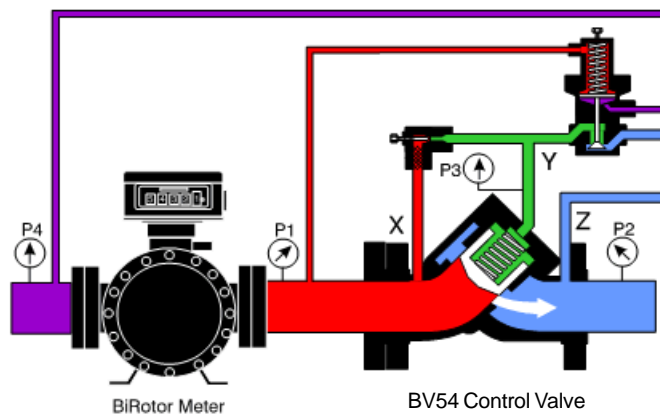

## Dimensions (For Certified Dimensional Prints - Consult Factory)

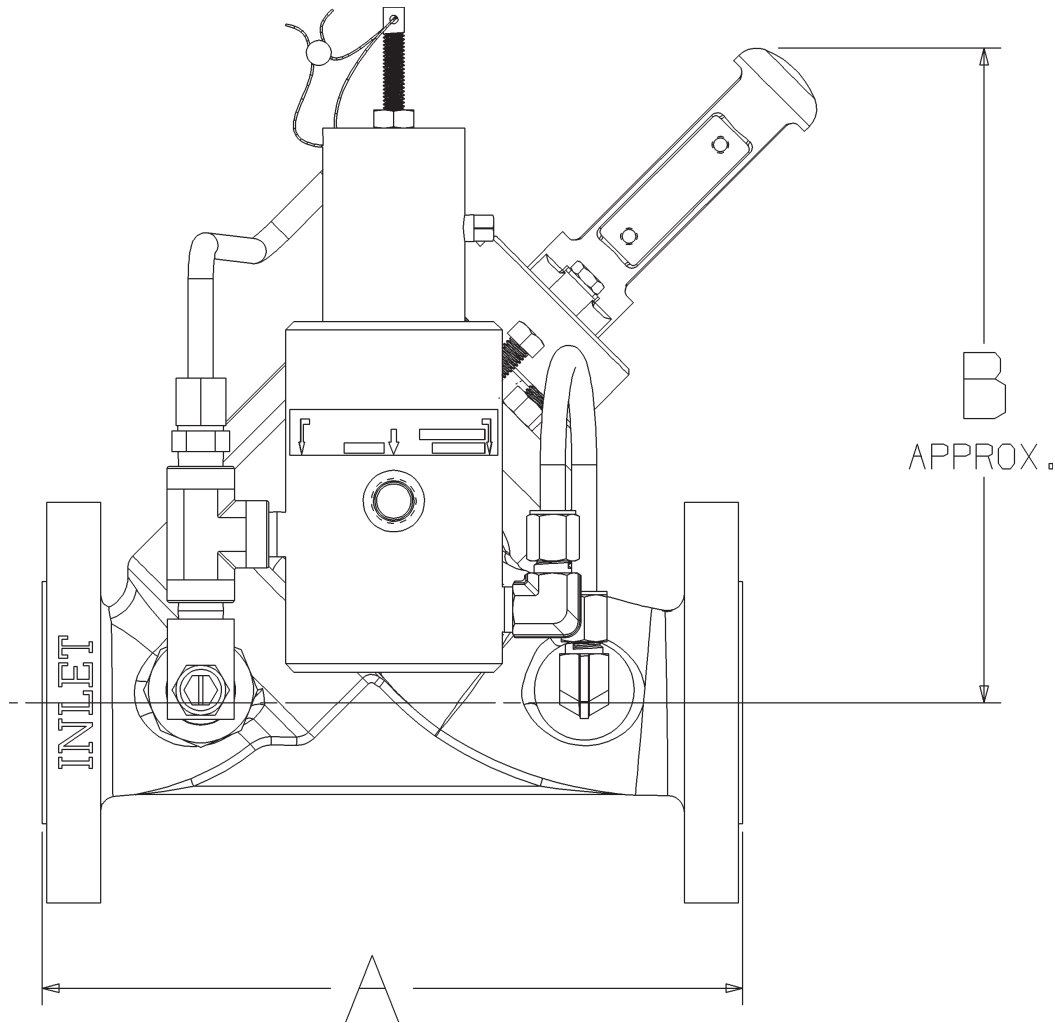

Valve Size		A Dimensions		B Dimensions
		150 lb.	300 lb.	150 & 300 lb.
2"	mm	260	267	276
	Inches	10 1/4	10 1/2	10 7/8
3"	mm	279	333	286
	Inches	11	13 1/8	11 1/4
4"	mm	330	368	292
	Inches	13	14 1/2	11 1/2
6"	mm	432	454	346
	Inches	17	17 7/8	13 5/8

*The contents of this publication are presented for informational purposes only, and while every effort has been made to ensure their accuracy, they are not to be construed as warranties or guarantees, express or implied, regarding the products or services described herein or their use or applicability. Brodie Meter Co., LLC reserves the right to modify or improve the designs or specifications of such products at any time without notice.*

**BRODIE**  
International

19267 Highway 301 North (30461)  
PO Box 450 • Statesboro, GA 30459-0450  
Phone: (912) 489-0200 • Fax: (912) 489-0294  
[www.brodieintl.com](http://www.brodieintl.com)