

Model BV89 Two-Stage Valve

Description

The Model BV89 Brodie Two-Stage Valve is normally closed and designed for precise, accurate control and shut-off of petroleum products. The valve controls a predetermined amount of product to guarantee smooth, positive shut-off. Operational functions may include low flow start-up when used with a time delay circuit or other system controls.

The Model BV89 - Two-Stage shut-off plus pressure control achieved by sensing and controlling valve outlet pressure.

Principle of Operation

Typical Control Systems consist of three primary pieces of equipment: flowmeter, preset counter (electronic or mechanical), and two-stage shut-off valve. The meter is the primary flow measuring device. The preset counter is used to determine the volume of liquid to be controlled by the valve at predetermined settings. The sequential switches of the batch controlling mechanism control the solenoid pilots of the control valve.

The control valve operates on a balanced piston principle. Electrically operated solenoid pilots position the valve piston by increasing or decreasing hydraulic pressure on the top of the piston as dictated by sequencing switches. When pressure on both sides of the valve piston is equal, the main valve spring acts as a differential force and closes the valve. When the pressure against the bottom of the piston exceeds the pressure (plus the force of the spring) exerted against the top of the piston, spring pressure is overcome and the valve is opened.

The control valve is designed to close in two distinct stages. As the preset counter reaches the first stage of shut-off, the preset trips the sequence switches to place the valve in the first stage (low flow) shut-off position. The first stage closure reduces the flow rate through the valve to

WARNING

Do NOT operate this instrument in excess of the specifications listed. Failure to heed this warning could result in serious injury and/or damage to the equipment.

approximately 10 to 20 percent of the rated capacity of the meter. The preset trips the sequencing switches again and the valve closes.

Design Features

- Precision flow rate and batch control
- Modular construction -all internal parts including seat ring can be removed with the cylinder assembly without disturbing line connections.
- No diaphragms or stuffing boxes
- 45° body design assures high capacity
- Positive shut-off
- Linear control characteristics with uniform response speed
- Automatic check valve - no reverse flow
- Fail-safe closes on loss of electrical power
- Characterized ports for better low flow response

Applications

Two-stage electrical control valves are suited for those applications requiring precise shut-off, such as truck or railcar loading or similar batching operations.

“AP” (Aggressive Products) Option

The “AP” option valve cylinder incorporates a combination of seals and O-ring materials to provide optimum performance in aggressive product applications. Specify “AP” Option at time of order when valve is to be used on products which may affect standard seals.

Materials of Construction

Main Valve Body: Steel - ASTM-A216-GR-WCB

Main Valve Cylinder: 17-4 PH Stainless Steel,
Heat Treated

Main Valve Piston: Stainless Steel

Seat Ring: Stainless Steel

O-Rings: Viton (Standard), Other Materials
(Optional)

Other Internal Parts: Stainless Steel

Pilot Valve Body: Steel (Standard)

Pilot Valve Trim: Stainless Steel

Tubings and Fittings: Steel (Standard)

Optional Equipment

- Pilot Line Isolation Block Valves
- Fusible Link Pilot Valve (closes at 160°F)
- Manual Override (Opens Valve)
- Adjustable Thermal Relief
- Closing Speed Control
- Low Flow Start-up

Recommended Spare Parts

O-Rings

Maximum Operating Pressure Differential (MOPD):

175 psi (1207.5 kPa) MOPD.

Flange Connections/Ratings (ANSI)

Valve Size	Connections	Max Working Pressure @100F
2" - 6"	150 lb. ANSI	285 PSI
	300 lb. ANSI	740 PSI

Temperature Range : -20F to 150F (-29C to 66C)

Valve Capacity Data

Valve Size	2"	3"	4"	6"
*Cv-gpm	90	190	315	700

**Cv based on wide open valve utilizing water at 60F (15.6C).*

Shipping Weight and Volume (150# ANSI)

Shipping Weight and Volume (Approximate)	
2"	69 lbs. @ 3 Cu. Feet 31.3 kgs. @ .085 Cu. Meters
3"	105 lbs. @ 2.36 Cu. Feet 47.63 kgs. @ .067 Cu. Meters
4"	140 lbs. @ 2.51 Cu. Feet 63.5 kgs. @ .071 Cu. Meters
6"	250 lbs. @ 4.84 Cu. Feet 113.4 kgs. @ .137 Cu. Meters

Ordering Information

When ordering, the following information must be supplied:

- Size
- Flange Connections
- Product, Product Viscosity, Product Specific Gravity
- Minimum and Maximum Flow Rate
- Minimum, Normal and Maximum Operating Temperature
- Control Functions to be Performed
- O-Ring Material
- Control Pilot Materials
- Tubing Material
- Pilot Spring Range
- Pilot Spring Setting (psi or kPa)

Typical Installation

Closed Position

The normally closed solenoid is closed. The normally open solenoid is open. Y-port (P3) to Z-port (P2) is closed. X-port (P1) and Y-port (P3) pressures are balanced. The main valve spring being the differential force, closes the piston and keeps it seated.

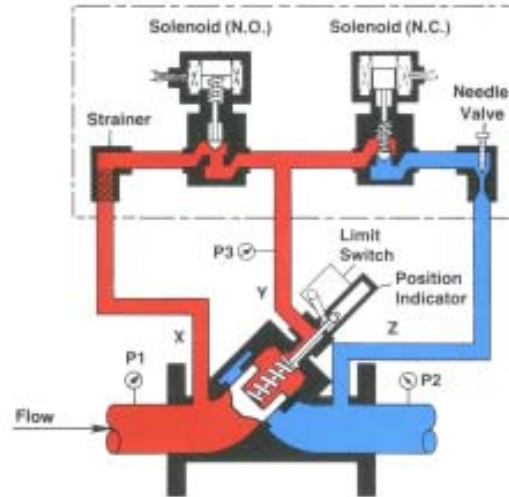

Fully Open - No Control

The normally closed solenoid is open. The normally open solenoid is closed. Y-port (P3) is open to Z-port (P2). X-port (P1) is closed off by the normally open solenoid. The pressure on the bottom of the piston (P1) is greater than the pressure at (P3) plus the spring force. $(P1 - P2)$ is equal to or greater than the spring force.

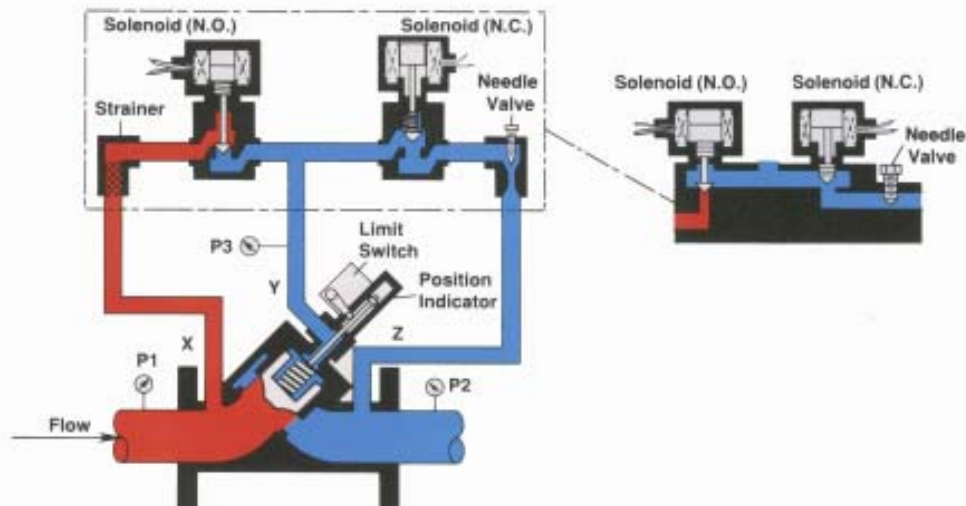

■ = Inlet Pressure
■ = Outlet Pressure

Low Flow Position

The normally closed solenoid is closed. The normally open solenoid is closed. Y-port (P3) to Z-port (P2) is closed. X-port (P1) to Y-port (P3) is closed. Note: The product cannot flow to or from the top of the piston (Y-port). The piston is locked hydraulically in the low flow position. During the transition stage from high flow to low flow, the normally closed solenoid was closed and the normally open solenoid was open (X-port/P1 /to Y-port/P3/was open). During the closing cycle, the limit switch was activated causing the N.O. solenoid to be closed hydraulically locking the valve in an intermediate position.

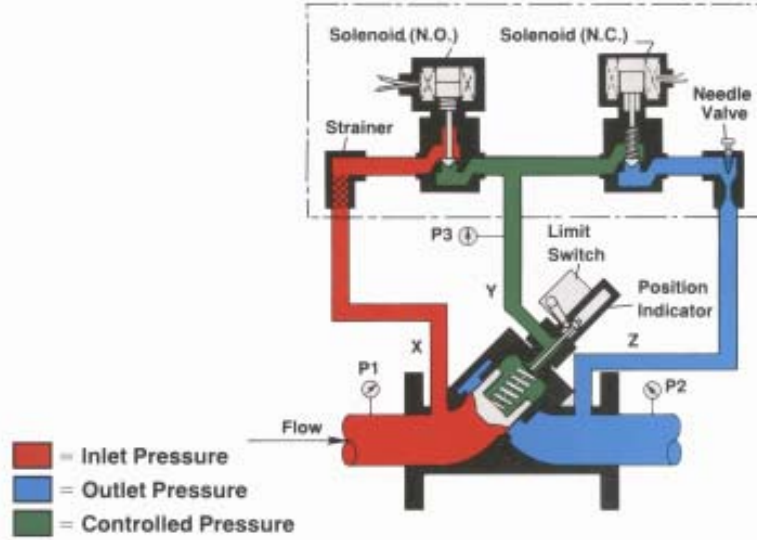

Dimensions (For Certified Dimensional Prints - Consult Factory)

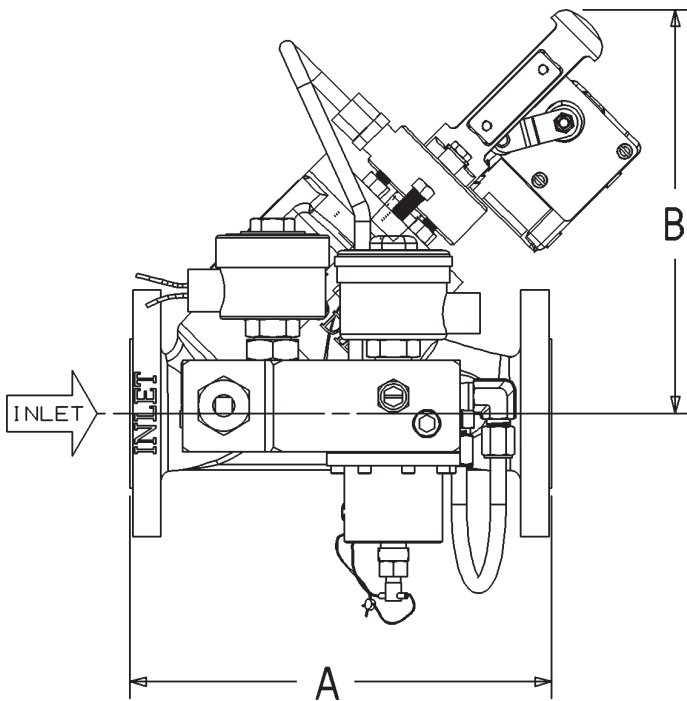

Valve Size	150# ANSI		
	A	B	
2"	mm	260	249
	Inches	10 1/4	9 13/16
3"	mm	279	273
	Inches	11	10 3/4
4"	mm	330	278
	Inches	13	10 15/16
6"	mm	432	400
	Inches	17	15 3/4

The contents of this publication are presented for informational purposes only, and while every effort has been made to ensure their accuracy, they are not to be construed as warranties or guarantees, express or implied, regarding the products or services described herein or their use or applicability. Brodie Meter Co., LLC reserves the right to modify or improve the designs or specifications of such products at any time without notice.